

For warnings and additional information see **MAGNUM dx Operation Manual 309225**.

INSTRUCTIONS

MAGNUM^t dx Lacquer Conversion Kit

by GRACO

KIT 248203

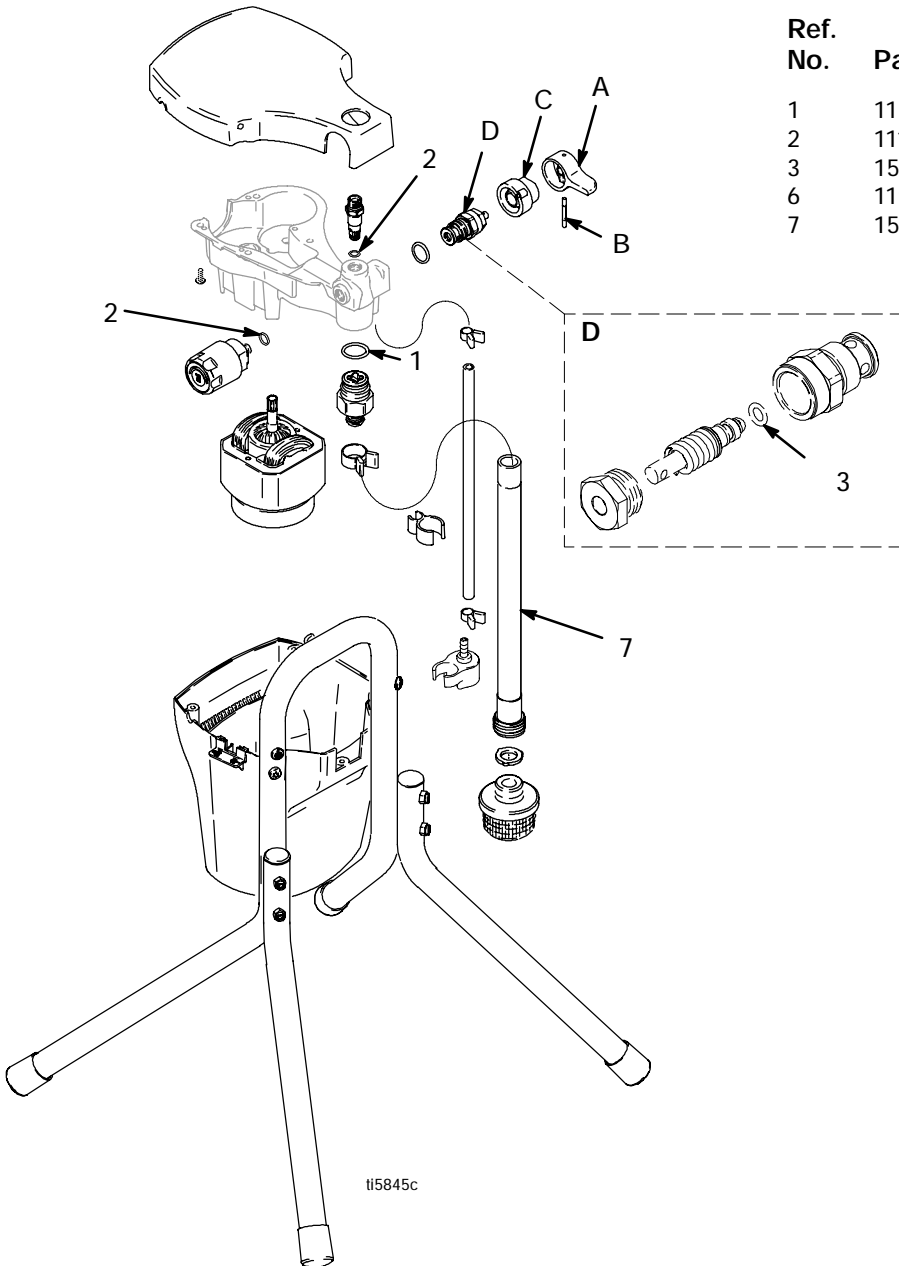

Ref. No.	Part No.	Description	Qty.
1	118233	O-RING, CV-75	1
2	111316	O-RING, CV-75, size 012	2
3	15D252	O-RING, CV-90, size 008	1
6	119400	SEALANT, pipe, sst	1
7	15A473	TUBE, suction	1

115845c

Instructions

1. To relieve pressure:

- Turn power switch OFF.
- Unplug sprayer.
- Turn Spray-Prime/Drain knob (A) down (Prime/Drain position).
- Hold metal part of gun firmly to a grounded metal pail. Pull gun trigger to relieve pressure.

2. Fig. 1. Turn knob (A) up to Spray position.

3. Remove pin (B) with 3/32 pin punch and hammer.

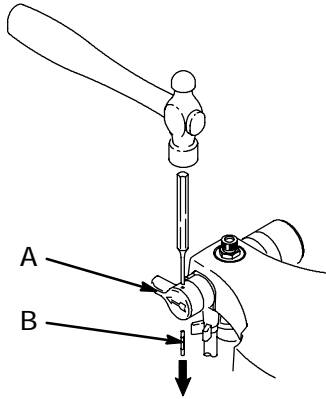

Fig. 1

4. Fig. 2. Remove knob (A) and base (C).

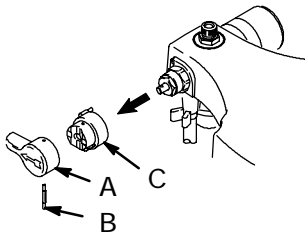

Fig. 2

5. Fig. 3. Remove valve stem (D) from pump manifold.

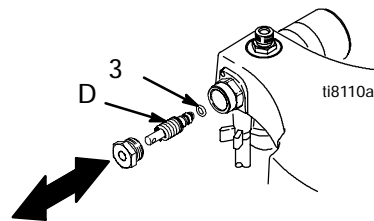

Fig. 3

6. Replace brown o-ring (3) on end of valve stem. Apply sealant (6) to valve threads. Install valve stem in pump manifold. Torque to 185 in-lb (21 N-m).

7. Fig. 4. Install base (C) on valve (D), aligning pin (E) on base with hole (F) on pump manifold.

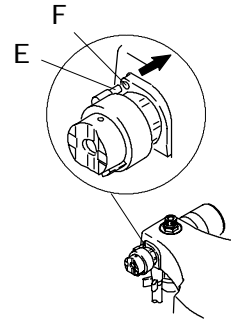

Fig. 4

8. Fig. 5. Rotate valve stem with 3/32 pin punch until hole is perpendicular.

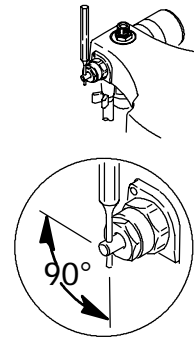

Fig. 5

9. Fig. 6. Install knob (A) over base (C).

10. Place knob in Spray position.

11. Insert end of pin punch through hole in knob (A), to make sure knob and valve stem are properly aligned.

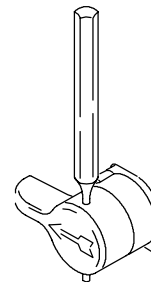

Fig. 6

12. Install pin (B) through hole in knob (A). Tap pin through knob with hammer. Correctly installed, end of pin is flush with top of hole in knob.

All written and visual data contained in this document reflect the latest product information available at the time of publication. Graco reserves the right to make changes at any time without notice.

This manual contains English: MM 310723

GRACO INC. P.O. BOX 1441 MINNEAPOLIS, MN 55440-1441

www.graco.com

03/2004, Revised 5/2006