



SS3L3

---

## Owner's Manual with Parts List

- EN Owner's Manual With Parts List
- ES Manual del propietario con la lista de piezas
- FR Manuel du propriétaire avec liste des pièces

**PORTLAND  
COMPRESSOR**  
*Experience You Can Depend On*  
800-542-8300



**Save These Instructions**

**IR** Ingersoll Rand®

---



---

**CONTENTS**

---

<b>SAFETY</b> .....	<b>4</b>	<b>MAINTENANCE</b> .....	<b>10</b>
<b>GENERAL SAFETY PRECAUTIONS</b> .....	<b>4</b>	<b>FILTER REPLACEMENT (SS3)</b> .....	<b>10</b>
<b>GENERAL INFORMATION</b> .....	<b>4</b>	OIL CHANGE .....	10
<b>RECEIPT &amp; INSPECTION</b> .....	<b>5</b>	BELT ADJUSTMENT .....	11
<b>INSTALLATION</b> .....	<b>6</b>	TANK INSPECTION .....	11
<b>SELECTING A LOCATION</b> .....	<b>6</b>	<b>TROUBLESHOOTING</b> .....	<b>12</b>
GENERAL .....	6	<b>WARRANTY AND LIMITATION OF LIABILITY</b> ....	<b>16</b>
TEMPERATURE .....	6	<b>WARRANTY</b> .....	<b>16</b>
HUMID AREAS .....	6	<b>LIMITATION OF LIABILITY</b> .....	<b>16</b>
NOISE CONSIDERATIONS .....	6	<b>SS3 BARE PARTS LIST</b> .....	<b>17</b>
PERMANENT MOUNTING .....	6	<b>SS3L3 PARTS LIST</b> .....	<b>20</b>
TYPICAL PERMANENT MOUNTING (CUSTOMER - SUPPLIED HARDWARE) .....	6	<b>KITS &amp; ACCESSORIES</b> .....	<b>22</b>
INSTALLING THE AIR INLET FILTER .....	6	EXTENDED WARRANTY KIT .....	22
<b>INSTALLING DISCHARGE PIPING</b> .....	<b>6</b>	INGERSOLL RAND SYNTHETIC LUBRICANT .....	22
<b>GENERAL REQUIREMENTS</b> .....	<b>7</b>	AIR FILTER ELEMENT .....	22
<b>CONDENSATE DISCHARGE PIPING</b> .....	<b>7</b>	STEP SAVER KITS .....	22
<b>ELECTRICAL WIRING</b> .....	<b>7</b>	CRANKCASE HEATER KIT .....	22
GENERAL .....	7	VIBRATION ISOLATOR PADS .....	22
WIRE SIZE .....	7	MULTIPURPOSE AIR HOSES .....	22
FUSES .....	7	Y- STRAINERS .....	22
<b>COMPRESSOR LUBRICATION</b> .....	<b>7</b>	AUTOMATIC DRAIN VALVE ADDITION KIT .....	22
SYNTHETIC LUBRICANT .....	7		
ALTERNATE LUBRICANTS .....	7		
FILLING PROCEDURES: .....	8		
INITIAL START-UP .....	8		
PRESSURE SWITCH .....	8		
<b>OPERATION</b> .....	<b>9</b>		
GENERAL .....	9		
NORMAL START-UP .....	9		
WHEN YOU ARE FINISHED: .....	9		

# **INGERSOLL-RAND**

## **AIR COMPRESSORS**

Ingersoll-Rand Company  
800-B Beaty Street  
P. O. Box 1803  
Davidson, NC 28036

1-800-AIR SERV  
(1-800-247-7378)  
www.air.ingersoll-rand.com

## **CONSUMER INFORMATION SHEET**

Thank you for purchasing an Ingersoll-Rand product. We trust that it will offer you many years of trouble-free service. If you encounter any problems or need assistance, please refer to the information provided in this sheet.

---

### **INSTALLATION, OPERATION, MAINTENANCE & TROUBLESHOOTING ISSUES**

---

Read the owner's manual first. Often this will clarify your understanding. If you still have problems, please call the toll-free hotline.

---

### **MISSING PARTS**

---

If parts are missing call the toll free hotline. Have the serial number, part number, model number and parts list (with missing parts circled) handy when you call. Your parts will be shipped immediately.

---

### **SHIPPING DAMAGE OR DEFECTIVE PARTS**

---

Each new product is inspected and in good condition prior to shipment from the factory. If your product was received in a condition that was less than satisfactory, or if you discover a defect that requires service or adjustment by qualified personnel, please contact your nearest authorized service representative.

**DO NOT RETURN THE PRODUCT  
TO YOUR RETAILER!**

**NOTE REGARDING  
EXTENSION CORDS**

To avoid power loss and  
overheating, use additional air  
hose instead of an extension  
cord.

**PARTS & SERVICE HOTLINE:  
1-800-AIR SERV  
(1-800-247-7378)**

## SAFETY

### DANGER

Indicates an imminently hazardous situation which, if not avoided, will result in death or serious injury.

### WARNING

Indicates a potentially hazardous situation which, if not avoided, could result in death or serious injury.

### CAUTION

Indicates a potentially hazardous situation which, if not avoided, may result in minor or moderate injury or property damage.

### NOTICE

Indicates information or a company policy that relates directly or indirectly to the safety of personnel or protection of property.

## ■ GENERAL SAFETY PRECAUTIONS

### DANGER

**Intake air can contain carbon monoxide or other contaminants. Will cause serious injury or death. Ingersoll Rand air compressors are not designed, intended or approved for breathing air. Compressed air should not be used for breathing air applications unless treated in accordance with all applicable codes and regulations.**

### WARNING

**A hazardous voltage can cause serious injury or death. Disconnect power and bleed pressure from the tank before servicing. Lockout/tagout machine. Compressor must be connected to properly grounded circuit. See grounding instructions in manual. Do not operate compressor in wet conditions. Store indoors.**

**Moving parts. Can cause serious injury. Do not operate with guards removed. Machine may start automatically. Disconnect power before servicing. Lockout/tagout machine.**

**Hot surfaces. Can cause serious injury. Do not touch. Allow to cool before servicing. Do not touch hot compressor or tubing.**

**High pressure air. Bypassing, modifying or removing safety/relief valves can cause serious injury or death. Do not bypass, modify or remove safety/relief valves. Do not direct air stream at body. Rusted tanks can cause explosion and severe injury or death. Drain tank daily or after each use. Drain valve located at bottom of tank.**

### CAUTION

**A caution risk of bursting. Use only suitable air handling parts acceptable for pressure of not less than the maximum allowable working pressure of the machine.**

## GENERAL INFORMATION

Your air compressor unit is suitable for operating air tools, caulking guns, grease guns, sandblasters, etc. Depending on your application, the following accessories may be required:

- An air pressure regulator to adjust the air pressure entering the tool or accessory.
- An air line filter for removal of moisture and oil vapor in compressed air.
- An in-line lubricator to prolong the life of air tools.

- Separate air transformers which combine the functions of air regulation and/or moisture and dirt removal.

Contact your nearest authorized dealer or call 1-800-AIR-SERV for more information on air tools and accessories for your application.

---

## RECEIPT & INSPECTION

---

Ensure adequate lifting equipment is available for unloading and moving the compressor to the installation site.

### NOTICE

**Lifting equipment must be properly rated for the weight of the unit.**

**Lift the unit by the shipping skid only. Use straps to prevent tipping.**

If you discover damage after receiving the unit (concealed damage), the carrier must be notified within 15 days of receipt and an inspection must be requested by telephone with confirmation in writing. On concealed damage claims, the burden of establishing that the unit was damaged in transit reverts back to the claimant.

Read the unit specification label to verify it is the model ordered, and read the motor nameplate to verify it is compatible with your electrical conditions. Make sure electrical enclosures and components are appropriate for your application.

### CAUTION

**Do not work on or walk under the compressor while it is suspended.**

Before signing the delivery receipt, inspect for damage and missing parts. If damage or missing parts are apparent, make the appropriate notation on the delivery receipt, then sign the receipt. Immediately contact the carrier for an inspection. All material must be held in the receiving location for the carrier's inspection. Delivery receipts that have been signed without a notation of damage or missing parts are considered to be delivered "clear." Subsequent claims are then considered to be concealed damage claims. Settle damage claims directly with the transportation company.

**PORTLAND  
COMPRESSOR**  
*Experience You Can Depend On*  
**800-542-8300**

## INSTALLATION

### ■ SELECTING A LOCATION

#### ■ GENERAL

Select a clean, dry, well-lighted indoor area with plenty of space for proper cooling air flow and accessibility. Locate the unit at least 12 inches (30 cm) from walls, and make sure the main power supply is clearly identified and accessible.

#### ■ TEMPERATURE

Ideal operating temperatures are between 32°F and 100°F (0°C and 37.8°C). If temperatures consistently drop below 32°F (0°C), locate the unit inside a heated building. If this is not possible, you must protect safety/relief valves and drain valves from freezing.

#### ⚠ CAUTION

**Never operate in temperatures below 20°F (-6.6°C) or above 125°F (51.0°C).**

#### ■ HUMID AREAS

In frequently humid areas, moisture may form in the bare pump and produce sludge in the lubricant, causing running parts to wear out prematurely. Excessive moisture is especially likely to occur if the unit is located in an unheated area that is subject to large temperature changes. Two signs of excessive humidity are external condensation on the bare pump when it cools down and a "milky" appearance in petroleum compressor lubricant. You may be able to prevent moisture from forming in the bare pump by increasing ventilation, operating for longer intervals or installing a crankcase heater kit.

#### ■ NOISE CONSIDERATIONS

Consult local officials for information regarding acceptable noise levels in your area. To reduce excessive noise, use vibration isolator pads or intake silencers, relocate the unit or construct total enclosures or baffle walls.

#### ■ PERMANENT MOUNTING

#### ⚠ WARNING

**Remove the unit from the skid before mounting.**

The unit must be permanently mounted. When mounting the unit, bolt the feet to a firm, level foundation (such as a concrete floor). Do not bolt uneven feet tightly to the foundation, as this will cause excessive stress on the receiver tank. Use metal shims under the "short" feet if necessary.

### ■ TYPICAL PERMANENT MOUNTING (CUSTOMER -SUPPLIED HARDWARE)

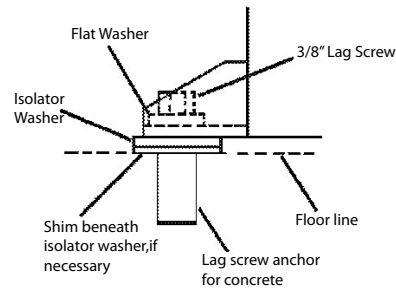

### ■ INSTALLING THE AIR INLET FILTER

#### ⚠ CAUTION

**Do not operate the unit without air inlet filter(s).**

If the air around the unit is relatively free of dirt, install the air inlet filter(s) at the inlet connection(s) at the bare pump. If remote air inlet piping or heavy duty filtration is required, contact your dealer for information.

### ■ INSTALLING DISCHARGE PIPING

If it is necessary to install air discharge and condensate discharge piping, adhere to the following general guidelines. Contact your dealer for more information.

#### ⚠ WARNING

**Do not use plastic pipe, rubber hose, or lead-tin soldered joints anywhere in the compressed air system.**

#### ⚠ WARNING

**If an aftercooler, check valve, block valve, or any other restriction is added to the compressor discharge, install a properly-sized ASME approved safety/relief valve between the compressor discharge and the restriction.**

#### ⚠ CAUTION

**If you will be using Ingersoll Rand synthetic compressor lubricant, all downstream piping material and system components must be compatible. Refer to the following material compatibility list. If there are incompatible materials present in your system, or if there are materials not included in the list, contact your dealer or call 1-800-AIR-SERV.**

**SYNTHETIC COMPRESSOR LUBRICANT MATERIAL COMPATIBILITY LIST**

**COMPATIBILITY LIST SUITABLE :**

FKM (Fluoroclastomer), PTFE, Epoxy (Glass Filled), Oil Resistant Alkyd, Fluorosilicone, Fluorocarbon, Polysulfide, 2-Component Urethane, Nylon, POM (Polyoxymethylene/Polyacetal), High Nitrile Rubber (Buna N. NBR more than 36% Acrylonitrile), Polyurethane, Polyethylene, Epichlorohydrin, Polyacrylate, Melamine, Polypropylene, Baked Phenolics, Epoxy, Modified Alkyds (® indicates trademark of DuPont Corporation).

**NOT RECOMMENDED :**

Neoprene, Natural Rubber, SBR Rubber, Acrylic Paint, Lacquer, Varnish, Polystyrene, PVC, ABS, Polycarbonate, Cellulose Acetate, Low Nitrile Rubber (Buna N. NBR less than 36% Acrylonitrile), EPDM, Ethylene Vinyl Acetate, Latex, EPR, Acrylics, Phenoxy, Polysulfones, Styrene Acrylonitrile (San), Butyl.

**GENERAL REQUIREMENTS**

The piping, fittings, air receiver tank, etc. must be certified safe for at least the maximum working pressure of the unit. Use hard-welded or threaded steel or copper pipes and cast iron fittings that are certified safe for the unit's discharge pressure and temperature. DO NOT USE PVC PLASTIC. Use pipe thread sealant on all threads, and make up joints tightly to prevent air leaks.

**CONDENSATE DISCHARGE PIPING**

If installing a condensate discharge line, the piping must be at least one size larger than the connection, as short and direct as possible, secured tightly and routed to a suitable drain point. Condensate must be disposed of in accordance with local, state, and federal laws and regulations.

**NOTICE**

All compressed air systems generate condensate which accumulates in any drain point (e.g. tanks, filters, drip legs, aftercoolers, dryers). This condensate contains lubricating oil and/or substances which may be regulated and must be disposed of in accordance with local, state, and federal laws and regulations.

**ELECTRICAL WIRING**

**WARNING**

Electrical installation and service should be performed by a qualified electrician who is familiar with all applicable local, state and federal laws and regulations.

**NOTICE**

This product should be connected to a grounded, metallic, permanent wiring system, or an equipment-grounding terminal or lead on the product.

**GENERAL**

The motor rating, as shown on the motor nameplate, and the power supply must have compatible voltage, phase and hertz characteristics.

**WIRE SIZE**

The electrical wiring between the power supply and electric motor varies according to motor horsepower. Power leads must be adequately sized

to protect against excessive voltage drop during start-up. Information for selecting the proper wire size and securing connections should be provided with the motor. If not, refer to the National Electric Code (NEC) or applicable local, state and federal laws and regulations. If other electrical equipment is connected to the same circuit, the total electrical load must be considered in selecting the proper wire size. DO NOT USE UNDERSIZE WIRE.

**FUSES**

Refer to the National Electric Code to determine the proper fuse or circuit breaker rating required. When selecting fuses, remember the momentary starting current of an electric motor is greater than its full load current. Time-delay or "slow-blow" fuses are recommended.

**Single-Phase Wiring**

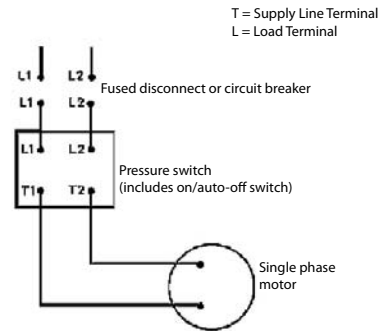

**COMPRESSOR LUBRICATION**

**CAUTION**

Do not operate without lubricant or with inadequate lubricant. Ingersoll Rand is not responsible for compressor failure caused by inadequate lubrication.

**SYNTHETIC LUBRICANT**

We recommend Ingersoll Rand synthetic compressor lubricant from start-up. See the WARRANTY section for extended warranty information.

**ALTERNATE LUBRICANTS**

You may use a petroleum-based lubricant that is premium quality, does not contain detergents, contains only anti-rust, anti-oxidation, and anti-foam agents as additives, has a flashpoint of 440°F (227°C) or higher, and has an auto-ignition point of 650°F (343°C) or higher.

See the petroleum lubricant viscosity table below. The table is intended as a general guide only. Heavy duty operating conditions require heavier viscosities. Refer specific operating conditions to your dealer for recommendations.

Temperature Around Compressor		Viscosity at 100°F (37.8 °C)		Viscosity Grade	
°F	°C	SUS	Centistokes	ISO	SAE
40 & below	4.4 & below	150	32	32	10
40-80	4.4-26.7	500	110	100	30
80-125	26.7-51.0	750	165	150	40

If you use a petroleum-based compressor lubricant at start-up and decide to convert to Ingersoll Rand synthetic compressor lubricant later on, the compressor valves must be thoroughly decarbonized and the crankcase must be flushed before conversion.

## ■ FILLING PROCEDURES:

1. Unscrew and remove the oil fill plug (A).
2. Slowly fill the crankcase with lubricant until the lubricant reaches the top thread of the oil fill opening and the top of the sight glass. Crankcase capacity for the SS3 is one-half (0.5) liter. Crankcase capacity for the SS5 is one (1) liter.
3. Replace the oil fill plug **HAND TIGHT ONLY**.

### Filling Procedures

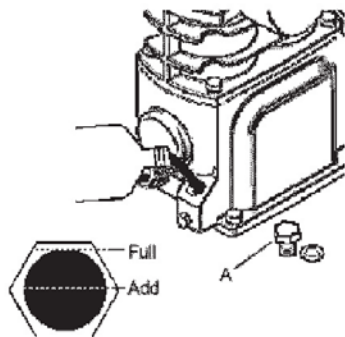

## ⚠ CAUTION

**Unusual noise or vibration indicates a problem. Do not continue to operate until you identify and correct the source of the problem. IF EMERGENCY CONDITIONS ARE ENCOUNTERED. SHUT OFF THE MAIN POWER IMMEDIATELY.**

5. After 30 minutes, close the service valve fully. The air receiver will fill to cut-out pressure and the motor will stop. The unit is now ready for use.

## ■ INITIAL START-UP

### ■ PRESSURE SWITCH

The Pressure Switch is Pre-set at the required pressure. The range and differential settings are not adjustable. The Pressure Switch should not be tampered with in any way and no attempt should be made to adjust the pressure settings as this could damage the Switch to the point of failure and/or void any warranty for the Pressure Switch.

Follow this procedure before putting the unit into service for the first time:

1. Set the pressure switch lever to "OFF".

#### • Pressure Switch Lever

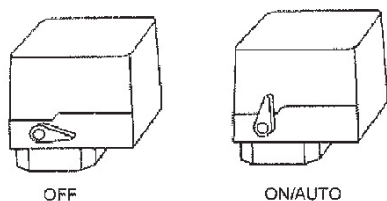

2. Open the service valve fully to prevent air pressure from building in the tank. (A=Open, B=Closed).

#### • Service Valve

3. Move the pressure switch lever to "ON/AUTO" The unit will start.
4. Run the unit for 30 minutes. Ensure the service valve is fully open and there is no tank pressure build up.

**PORTLAND  
COMPRESSOR**  
Experience You Can Depend On  
800-542-8300



---

## OPERATION

---

### ■ GENERAL

Your air compressor was designed for 100% continuous duty operation with the use of **Ingersoll Rand** synthetic compressor lubricant and 60% continuous duty operation with the use of petroleum lubricant. In other words, synthetic lubricant allows the compressor to pump continuously without cycling. Petroleum lubricant limits the compressor to a maximum of 36 minutes of pumping time per hour. The compressor should not cycle more than 10 times per hour.

### ■ NORMAL START-UP

1. Set the pressure switch lever to "OFF".
2. Close the service valve.
3. Attach hose and accessory.
4. Move the pressure switch lever to "ON/AUTO". The unit will start.
5. Allow tank pressure to build. The motor will stop when tank pressure reaches cut-out pressure.
6. Open the service valve. The unit is now ready for use.

### ■ WHEN YOU ARE FINISHED:

1. Set the pressure switch lever to "OFF".
2. Close the service valve fully.
3. Remove the air tool or accessory.
4. Slowly open the service valve to bleed air pressure down to 20 psig.
5. Slowly open the manual drain valve at the bottom of the tank to drain all condensate (water).
6. Close the drain valve and the service valve for the next use.

### NOTICE

**When the receiver tank pressure drops below the factory pre-set minimum, the pressure switch resets and restarts the unit.**

**PORTLAND  
COMPRESSOR**  
*Experience You Can Depend On*  
**800-542-8300**

## MAINTENANCE

### ⚠ WARNING

**Disconnect, lock and tag the main power supply and release air pressure from the system before performing maintenance.**

### NOTICE

**All compressed air systems contain maintenance parts (e.g. lubricating oil, filters, separators) which are periodically replaced. These used parts may be, or may contain, substances that are regulated and must be disposed of in accordance with local, state, and federal laws and regulations.**

### NOTICE

**Take note of the positions and locations of parts during disassembly to make reassembly easier. The assembly sequences and parts illustrated may differ for your particular unit.**

### NOTICE

**Any service operations not explained in this manual should be performed by an authorized service representative.**

### ROUTINE MAINTENANCE SCHEDULE

Daily or Before Each Operation	Check lubricant level. Fill as needed.
	Drain receiver tank condensate. Open the manual drain valve and collect and dispose of condensate accordingly.
	Check for unusual noise and vibration.
	Ensure beltguards and covers are securely in place.
	Ensure area around compressor is free from rags, tools, debris, and flammable or explosive materials.
Weekly	Inspect air filter element. Clean or replace if necessary.
Monthly	Inspect for air leaks. Squirt soapy water around joints during compressor operation and watch for bubbles.
	Check tightness of screws and bolts. Tighten as needed.
	Clean exterior.
3/500*	Change petroleum lubricant while crankcase is warm.
12/2000 *	Change synthetic lubricant while crankcase is warm.
	Replace filter element.
* indicates months/operating hours, whichever occurs first.	

### ■ FILTER REPLACEMENT (SS3)

1. Unscrew and remove the wing nut (A).
2. Remove the filter cover (B), baffle (C) and element (D) from the base (E).
3. Install a new element and reassemble the filter assembly.

### NOTICE

**The air intake holes in the baffle and cover must be staggered 180°. When reinstalling the assembly at the inlet connection, ensure the intake hole in the cover is on the bottom to minimize the entry of foreign matter from the air.**

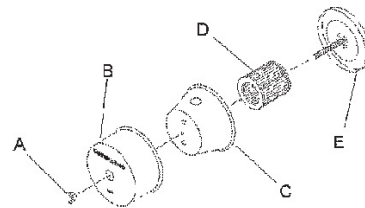

### ■ OIL CHANGE

1. Remove the oil drain plug (A) and allow the lubricant to drain into a suitable container.
2. Replace the oil drain plug.
3. Follow the filling procedures in OPERATION section.

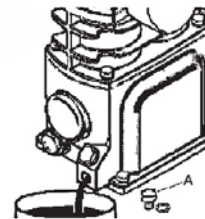

## ■ BELT ADJUSTMENT

### • CHECKING BELT TENSION

Check belt tension occasionally, especially if looseness is suspected. A quick check to determine if adjustment is proper may be made by observing the slack side of the belt for a slight bow when the unit is in operation. If a slight bow is evident, the belt is usually adjusted satisfactorily.

### • TENSIONING BELTS

Belt tensioning can be achieved by loosening the motor anchor screws, pushing the motor away from the pump, and retightening the motor anchor screws. The motor can be easily moved by placing a prying tool beneath it. A commercially available spreader or other belt tensioning device can also be helpful should tensioning be necessary.

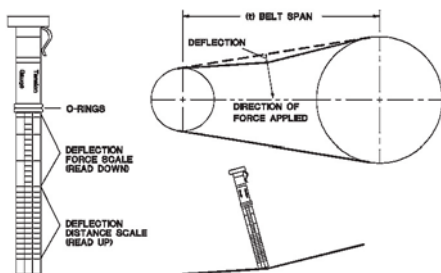

Follow the procedures outlined below to correctly set and measure belt tension.

1. Lay a straight edge across the top outer surface of the belt drive from pulley to sheave.
2. At the center of the span, perpendicular to the belt, apply pressure to the outer surface of the belt with a tension gauge. Force the belt to the deflection indicated in the table below. Compare the reading on the tension gauge to the following table.

Deflection In Inches	Min. Tension (Lbs.)	Max. Tension (Lbs.)
0.17	3.0	6.0

Ensure the pulley and sheave are properly aligned and the motor anchor screws are adequately retightened prior to restarting the compressor.

## ⚠ CAUTION

**Improper pulley/sheave alignment and belt tension can result in motor overload, excessive vibration, and premature belt and/or bearing failure.**

**To prevent these problems from occurring, ensure the pulley and sheave are aligned and belt tension is satisfactory after installing new belts or tensioning existing belts.**

## ■ TANK INSPECTION

The life of an air receiver tank is dependent upon several factors including, but not limited to, operating conditions, ambient environments, and the level of maintenance. The exact effect of these factors on tank life is difficult to predict; therefore, **Ingersoll Rand** recommends that you schedule a certified tank inspection within the first five years of compressor service. To arrange a tank inspection, contact the nearest IR Air Center or distributor, or call 1-800-AIR SERV.

If the tank has not been inspected within the first 10 years of compressor service, the receiver must be taken out of service until it has passed inspection. Tanks that fail to meet requirements must be replaced.

## ⚠ WARNING

**Failure to replace a rusted air receiver tank could result in air receiver tank rupture or explosion, which could cause substantial property damage, severe personal injury, or death. Never modify or repair tank. Obtain replacement from service center.**

## TROUBLESHOOTING

PROBLEM	POSSIBLE CAUSE	POSSIBLE SOLUTION
Abnormal piston, ring or cylinder wear.	Lubricant viscosity too low	Drain existing lubricant and refill with proper lubricant.
	Lubricant level too low	Add lubricant to crankcase to proper level.
	Detergent type lubricant being used	Drain existing lubricant and refill with proper lubricant
	Cylinder(s) or piston(s) scratched worn or scored.	Repair or replace as required
	Extremely dusty atmosphere.	Install remote air inlet piping and route to source of cleaner air. Install more effective filtration.
	Worn cylinder finish	Deglaze cylinder with 180 grit flex-hone.
Air delivery drops off	Clogged or dirty inlet and / or discharge line filter	Clean or replace
	Air leaks in air discharge piping.	Check tubing and connections.
	Lubricant viscosity too high.	Drain existing lubricant and refill with proper lubricant.
	Compressor valves leaky, broken, carbonized or loose.	Inspect valves. Clean or replace as required. Install valve kit.
	Piston rings damaged or worn (broken, rough or scratched). Excessive end gap or side clearance.	Install ring kit.
	Piston rings not seated, are stuck in grooves or end gaps not staggered.	Adjust piston rings
	Cylinder(s) or piston(s) scratched, worn or scored.	Repair or replace as required
	Defective safety/relief valve.	Replace
Unit does not come up to speed	Loose beltwheel or motor pulley, excessive end play in motor shaft or loose drive belts.	Check beltwheel, motor pulley, crankshaft, drive belt tension and alignment. Repair or replace as required.
	Lubricant viscosity too high	Drain existing lubricant and refill with proper lubricant.
	Improper line voltage	Check line voltage and upgrade lines as required. Contact electrician.
	Compressor valves leaky, broken, carbonized or loose.	Inspect valves. Clean or replace as required. Install valve kit.
	Defective ball bearings on crankshaft or motor shaft.	Inspect bearings and replace crankshaft assembly if required.
Unit is slow to come up to speed	Lubricant viscosity too high	Drain existing lubricant and refill with proper lubricant.
	Leaking check valve or check valve seat blown out.	Replace check valve.
	Ambient temperature too low.	Relocate unit to warmer environment. Install crankcase heater kit.
	Bad motor.	Replace.
Unit runs excessively hot	Inadequate ventilation around beltwheel.	Relocate unit for better air flow
	Drive belts too tight or misaligned	Adjust belts to proper tension and alignment.
	Compressor valves leaky, broken, carbonized or loose	Inspect valves. Clean or replace as required. Install valve kit.
	Wrong beltwheel direction of rotation	Check motor wiring for proper connections. Reverse two leads on three-phase motors.

PROBLEM	POSSIBLE CAUSE	POSSIBLE SOLUTION
Excessive noise during operation	Loose beltwheel or motor pulley, excessive end play in motor shaft or loose drive belts.	Check beltwheel, motor pulley, crankshaft, drive belt tension and alignment. Repair or replace as required.
	Lubricant viscosity too high	Drain existing lubricant and refill with proper lubricant
	Lubricant level too low	Add lubricant to crankcase to proper level
	Compressor valves leaky, broken, carbonized or loose.	Inspect valves. Clean or replace as required. Install valve kit
	Carbon build-up on top of piston(s).	Clean piston(s). Repair or replace as required.
	Defective ball bearings on crankshaft or motor shaft.	Inspect bearings and replace crankshaft assembly if required
	Leaking check valve or check valve seat blown out.	Replace check valve.
Excessive starting and stopping	Air leaks in air discharge piping.	Check tubing and connections
	Leaking check valve or check valve seat blown out.	Replace check valve
	Excessive condensate in receiver tank	Drain receiver tank with manual drain valve
High oil consumption	Clogged or dirty inlet and/or discharge line filter.	Clean or replace
	Lubricant viscosity too low	Drain existing lubricant and refill with proper lubricant
	Detergent type lubricant being used	Drain existing lubricant and refill with proper lubricant
	Piston rings damaged or worn (broken, rough or scratched). Excessive end gap or side clearance	Install ring kit
	Piston rings not seated, are stuck in grooves or end gaps not staggered	Adjust piston rings
	Cylinder(s) or piston(s) scratched, worn or scored	Repair or replace as required
	Connecting rod, piston pin or crankpin bearings worn or scored	Inspect all. Repair or replace as required
	Crankshaft seal worn or crankshaft scored	Replace seal or crankshaft assembly
	Worn cylinder finish	Deglaze cylinder with 180 grit flex-hone
Knocking or rattling	Loose beltwheel or motor pulley, excessive end play in motor shaft or loose drive belts.	Check beltwheel, motor pulley, crankshaft, drive belt tension and alignment. Repair or replace as required.
	Compressor valves leaky, broken, carbonized or loose.	Inspect valves. Clean or replace as required. Install valve kit
	Carbon build-up on top of piston(s).	Clean piston(s). Repair or replace as required.
	Cylinder(s) or piston(s) scratched, worn or scored	Repair or replace as required
	Connecting rod, piston pin or crankpin bearings worn or scored	Inspect all. Repair or replace as required
	Defective ball bearings on crankshaft or motor shaft.	Inspect bearings and replace crankshaft assembly if required

PROBLEM	POSSIBLE CAUSE	POSSIBLE SOLUTION
Lights flicker or dim when running	Improper line voltage	Check line voltage and upgrade lines as required. Contact electrician.
	Wiring or electric service panel too small	Install properly sized wire or service box. Contact electrician.
	Poor contact on motor terminals or starter connections	Ensure good contact on motor terminals or starter connections
	Improper starter overload heaters	Install proper starter overload heaters. Contact electrician
	Poor power regulation (unbalanced line)	Contact power company
Moisture in crankcase or "milky" appearance in petroleum lubricant or rusting in cylinders	Detergent type lubricant being used	Drain existing lubricant and refill with proper lubricant
	Extremely light duty cycles	Run unit for longer duty cycles
	Unit located in damp or humid location	Relocate unit
Motor overload trips or draws excessive current	Lubricant viscosity too high	Drain existing lubricant and refill with proper lubricant
	Improper line voltage	Check line voltage and upgrade lines as required. Contact electrician.
	Wiring or electric service panel too small	Install properly sized wire or service box. Contact electrician.
	Poor contact on motor terminals or starter connections	Ensure good contact on motor terminals or starter connections
	Improper starter overload heaters	Install proper starter overload heaters. Contact electrician
	Poor power regulation (unbalanced line)	Contact power company
	Drive belts too tight or misaligned	Adjust belts to proper tension and alignment.
	Compressor valves leaky, broken, carbonized or loose	Inspect valves. Clean or replace as required. Install valve kit
	Cylinder(s) or piston(s) scratched, worn or scored	Repair or replace as required
	Connecting rod, piston pin or crankpin bearings worn or scored	Inspect all. Repair or replace as required
	Defective ball bearings on crankshaft or motor shaft.	Inspect bearings and replace crankshaft assembly if required
	Leaking check valve or check valve seat blown out.	Replace check valve.
	Ambient temperature too low.	Relocate unit to warmer environment. Install crankcase heater kit.
Bad motor.	Replace.	
Motor will not start	Improper line voltage	Check line voltage and upgrade lines as required. Contact electrician.
	Wiring or electric service panel too small	Install properly sized wire or service box. Contact electrician.
	Poor contact on motor terminals or starter connections	Ensure good contact on motor terminals or starter connections
	Improper starter overload heaters	Install proper starter overload heaters. Contact electrician
	Bad motor	Replace

PROBLEM	POSSIBLE CAUSE	POSSIBLE SOLUTION
Oil in discharge air (oil pumping)	Lubricant viscosity too low	Drain existing lubricant and refill with proper lubricant
	Detergent type lubricant being used	Drain existing lubricant and refill with proper lubricant
	Piston rings damaged or worn (broken, rough or scratched). Excessive end gap or side clearance	Install ring kit
	Piston rings not seated, are stuck in grooves or end gaps not staggered	Adjust piston rings
	Cylinder(s) or piston(s) scratched, worn or scored	Repair or replace as required
	Worn cylinder finish	Deglaze cylinder with 180 grit flex-hone
	Excessive condensate in receiver tank	Drain receiver tank with manual drain valve
Oil leaking from shaft seal	Crankshaft seal worn or crankshaft scored	Replace seal or crankshaft assembly
Safety/relief valve "pops"	Clogged or dirty inlet and / or discharge line filter	Clean or replace
	Compressor valves leaky, broken, carbonized or loose.	Inspect valves. Clean or replace as required. Install valve kit
	Defective safety/relief valve	Replace

**PORTLAND  
COMPRESSOR**  
Experience You Can Depend On  
800-542-8300

---



---

## WARRANTY AND LIMITATION OF LIABILITY

---

### ■ WARRANTY

**Ingersoll Rand** company warrants that the equipment manufactured by it and delivered hereunder shall be free of defects in material and workmanship for a period of twelve (12) months from the date of placing the equipment in operation or eighteen (18) months from the date of shipment, whichever shall occur first. The foregoing warranty period shall apply to all equipment, except the following:

1. Compressors purchased with an accompanying Extended Warranty Kit that are operated solely on the included **Ingersoll Rand** synthetic lubricant will have their bare compressor warranted for the earlier of twenty-four (24) months from the date of initial operation or thirty (30) months from the date of shipment.
2. Replacement parts will be warranted for six (6) months from the date of shipment.

Should any failure to confirm this warranty be reported in writing to the company within said period, the company shall, at its option, correct such non-conformity by suitable repair to such equipment, or furnish a replacement part F.O.B point of shipment, provided the purchaser has installed, maintained and operated such equipment in accordance with good industry practice and has complied with specific recommendations of the company. Accessories or equipment furnished by the company, but manufactured by others, shall carry whatever warranty the manufacturer conveyed to **Ingersoll Rand** Company and which can be passed on to the purchaser. The company shall not be liable for any repairs, replacements, or adjustments to the equipment or any costs of labour performed by the purchaser without company's prior written approval.

The company makes no performance warranty unless specifically stated within its proposal and the effects of corrosion, erosion and normal wear and tear are specifically excluded from the company's warranty. In the event performance warranties are expressly included, the company's obligation shall be to correct in the manner and for the period of time provided above.

**THE COMPANY MAKES NO OTHER WARRANTY OF REPRESENTATION OF ANY KIND WHATSOEVER, EXPRESSED OR IMPLIED, EXCEPT THAT OF TITLE, AND ALL IMPLIED WARRANTIES OF MERCHANTABILITY AND FITNESS FOR A PARTICULAR PURPOSE, AND HEREBY DISCLAIMED.**

Correction by the company of non-conformities, whether patent or latent, in the manner and for the period of time provided above, shall constitute fulfillment of all liabilities of the company and its distributors for such non-conformities with respect to or arising out of such equipment.

### ■ LIMITATION OF LIABILITY

THE REMEDIES OF THE PURCHASER SET FORTH HEREIN ARE EXCLUSIVE, AND THE TOTAL LIABILITY OF THE COMPANY, ITS DISTRIBUTORS AND SUPPLIERS WITH RESPECT TO CONTRACT OR THE EQUIPMENT AND SERVICES FURNISHED, IN CONNECTION WITH THE PERFORMANCE OR BRANCH THEREOF, OR FROM THE MANUFACTURE, SALE, DELIVERY, INSTALLATION, REPAIR OR TECHNICAL DIRECTION COVERED BY OR FURNISHED UNDER CONTRACT, WHETHER BASED ON CONTRACT, WARRANTY, NEGLIGENCE, INDEMNITY, STRICT LIABILITY OR OTHERWISE SHALL NOT EXCEED THE PURCHASE PRICE OF THE UNIT OF EQUIPMENT UPON WHICH SUCH LIABILITY IS BASED.

THE COMPANY, ITS DISTRIBUTORS AND ITS SUPPLIERS SHALL IN NO EVENT BE LIABLE TO THE PURCHASER, ANY SUCCESSORS IN INTEREST OR ANY BENEFICIARY OR ASSIGNEE OF THE CONTRACT FOR ANY CONSEQUENTIAL, INCIDENTAL, INDIRECT, SPECIAL OR PUNITIVE DAMAGES ARISING OUT OF THIS CONTRACT OR ANY BREACH THEREOF, OR ANY DEFECT IN, OR FAILURE OF, OR MALFUNCTION OF THE EQUIPMENT, WHETHER OR NOT BASED UPON LOSS OF USE, LOSS PROFITS OR REVENUE, INTEREST, LOST GOODWILL, WORK STOPPAGE, IMPAIRMENT OF THE OTHER GOODS, LOSS BY REASON OF SHUTDOWN OR NON-OPERATION, INCREASED FOR SERVICE INTERRUPTION WHETHER OR NOT SUCH LOSS OR DAMAGE IS BASED ON CONTRACT, WARRANTY, NEGLIGENCE, INDEMNITY, STRICT LIABILITY OR OTHERWISE.

**Questions ? Parts ? Service ?**

**1-800 AIR SERV**

**Visit our website:**

**[www.air.ingersoll-rand.com](http://www.air.ingersoll-rand.com)**



SS3 BARE PARTS LIST



Ingersoll-Rand Company  
 800-B Beaty Street  
 P. O. Box 1803  
 Davidson, NC 28036

PARTS LIST  
 FOR MODEL SS3  
 BARE COMPRESSOR PUMP

LISTA DE PIEZAS  
 PARA MODELO SS3  
 BOMBA COMPRESORA SIN  
 ACCESORIOS

LISTE DE PIÈCES  
 POUR COMPRESSEUR NU,  
 MODÈLE SS3

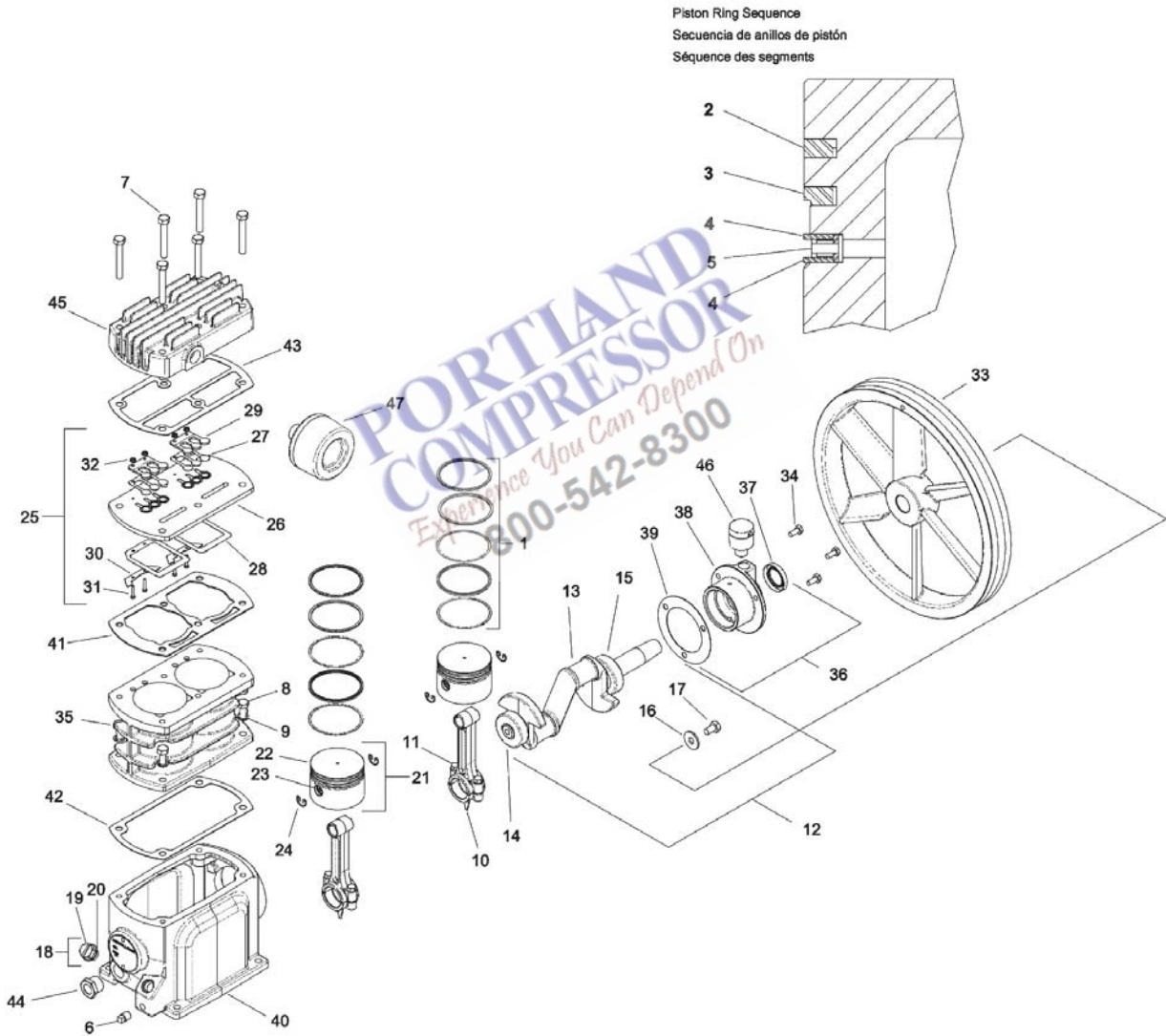

	REF. NO. N° DE REF. N° DE REP.	PART NO. N° DE PIEZA N° DE PIÉCE	DESCRIPTION	QTY. CANT. QTÉ.
	REF.	97330419	PUMP, BARE COMPRESSOR	-
X	1	32307092	SET, PISTON RING	2
	2	NSS	●RING, COMPRESSION	1
	3	NSS	●RING, SCRAPER	1
	4	NSS	●RING, OIL CONTROL SPACER	2
	5	NSS	●RING, OIL CONTROL	1
	6	95033585	PLUG, OIL DRAIN	1
	7	96715784	CAPSCREW. M8X55 (HEAD BOLT)	6
	8	96716113	CAPSCREW. M8 X20 (CYLINDER BOLT)	4
	9	96728316	WASHER. SPRING- M8	4
	10	97330427	ASSEMBLY, CONNECTING ROD	2
	11	96702246	●CAPSCREW, M8 X 25	2
	12	97338081	ASSEMBLY, CRANKSHAFT - SERVICE	1
	13	NSS	●CRANKSHAFT	1
	14	NSS	●BEARING, MAIN	1
	15	NSS	●BEARING, BALL	1
	16	54375977	●WASHER, M8	1
	17	54440045	●CAPSCREW, M8 X 20 - LEFT HAND THREAD	1
	18	49812050	ASSEMBLY, OIL FILL PLUG	1
	19	NSS	●PLUG, OIL FILL	1
	20	95024394	●O-RING, OIL FILL PLUG	1
	21	97330468	ASSEMBLY, PISTON & PIN	2
	22	NSS	●PISTON	1
	23	NSS	●PIN, PISTON	1
	24	NSS	●RING, LOCK	2
□	25	97330484	ASSEMBLY, VALVE	1
	26	NSS	●PLATE, VALVE	1
	27	NSS	●VALVE, DISCHARGE	2
	28	NSS	●VALVE, INLET	2
	29	NSS	●STOP, DISCHARGE	2
	30	NSS	●RETAINER, INLET	2
	31	NSS	●SCREW, HEX HEAD - M3 X 16	4
	32	NSS	●NUT, HEX - M3 W/LOCKWASHER	4
	33	97330492	BELT WHEEL	1
	34	97330500	CAPSCREW, M6 X 14 (END COVER BOLTS)	3
	35	97330625	CYLINDER	1
	36	97338073	ASSEMBLY, END COVER - SERVICE	1
	37	32204521	●SEAL, SHAFT	1
	38	NSS	●COVER END	1
	39	97331227	●GASKET, END COVER	1
	40	97330641	FRAME, COMPRESSOR	1
□	41	97330658	GASKET, VALVE PLATE	1
X	42	97330666	GASKET, CYLINDER	1

EN

<input type="checkbox"/>	43	54571609	GASKET, HEAD	1
	44	97330682	GLASS, SIGHT	1
	45	97330690	HEAD	1
	46	70243936	ASSEMBLY, VENT	1
	47	70243399	FILTER, INLET	1
	NI	70243712	●ELEMENT, FILTER	1
NSS NOT SOLD SEPARATELY <input type="checkbox"/> AVAILABLE INDIVIDUALLY OR IN VALVE KIT 97338107 <input checked="" type="checkbox"/> AVAILABLE INDIVIDUALLY OR IN PISTON RING KIT 97338115				

**PORTLAND  
COMPRESSOR**  
*Experience You Can Depend On*  
**800-542-8300**

**SS3L3 PARTS LIST**

**INGERSOLL-RAND®**  
**AIR COMPRESSORS**

Ingersoll-Rand Company  
 800-B Beaty Street  
 P. O. Box 1803  
 Davidson, NC 28036

**PARTS LIST  
 FOR  
 MODEL SS3L3  
 SINGLE STAGE  
 AIR COMPRESSOR**

**LISTA DE PIEZAS  
 PARA COMPRESOR DE AIRE  
 MONOCOMPRESIONAL  
 MODELO SS3L3**

**LISTE DE PIÈCES  
 POUR  
 COMPRESSEUR D'AIR  
 À UN ÉTAGE,  
 MODÈLE SS3L3**

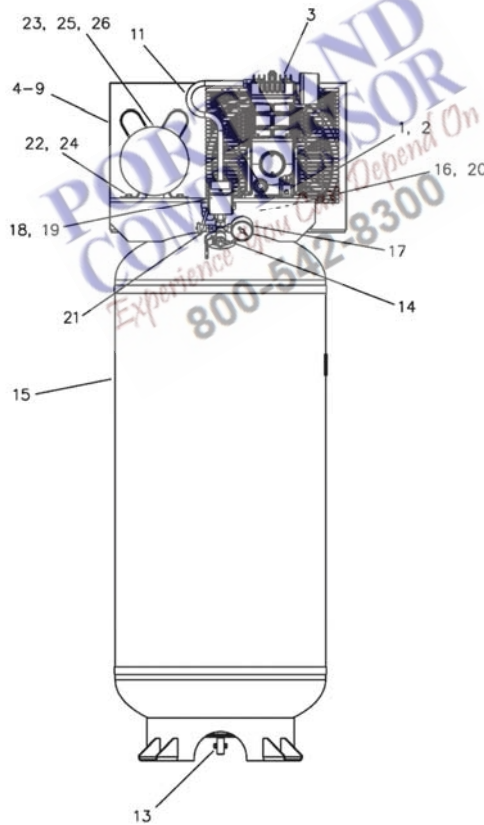

REF. NO.	PART NO.	DESCRIPTION	QTY.
1	32175788	CAPSCREW, 5/16 - 18 X 1 - SERRATED WASHER HEAD	4
2	39128558	NUT, WHIZ - LOCK -5/16 - 18	4
3	97330419	PUMP, BARE COMPRESSOR (SEE SEPARATE PARTS LIST FOR BREAKDOWN)	1
<b>BELTGUARD GROUP</b>			
4	56290869	SPACER, RUBBER	2
5	56269574	BRACE, BELTGUARD	1
6	56280159	SCREW, HEX- SERRATED FLANGE- M6-1.0X 12MM	1
7	54459508	BELTGUARD, FRONT	1
8	54459516	BELTGUARD, BACK	1
9	97173595	CAPSCREW, SELF TAP -1/4-20X1/2	7
<b>TUBING &amp; FITTINGS GROUP</b>			
10	95083192	CONNECTOR, MALE - 1/2 X 3/8	1
11	97336127	ASSY, DISCHARGE TUBE - 1/2	1
12	97336135	ASSY, VENT TUBE - 1/4	1
<b>AIR RECEIVER TANK GROUP</b>			
13	32027120	VALVE, MANUAL DRAIN	1
14	32106551	VALVE, BALL- 1/2 F/F (SERVICE VALVE)	1
15	32336042	TANK, AIR RECEIVER	1
16	56269590	VALVE, CHECK- 1/2 NPT X 1/2 INV. FLARE	1
17	56269608	GAUGE, PRESSURE - 160 PSI - 1/8 @ 9 O'CLOCK	1
18	56289671	SWITCH, PRESSURE-135 PSI	1
19	97004030	CONNECTOR CABLE	1
20	56269624	FITTING, MANIFOLD	1
21	97171664	VALVE, SAFETY/RELIEF - 1/8 NPT	2
<b>MOTOR GROUP</b>			
22	32164634	CAPSCREW, 5/16 X 3/4 SERRATED WASHER HEAD	4
23	32204208	SET,SHEAVE - 1A4.2 X .625	1
24	39128558	NUT, WHIZ-LOCK-5/16-18	4
25	56283138	MOTOR	1
26	95859112	BELT, V- 4L50	1

## KITS & ACCESSORIES

### ■ EXTENDED WARRANTY KIT

Each extended warranty kit contains air filters and all season select lubricant sufficient for two years operation.

Part No.	Description
97338099	Kit, Extended Warranty

### ■ INGERSOLL RAND SYNTHETIC LUBRICANT

Part No.	Description
97338131	Lubricant, 5L Bottle
97338149	Lubricant, 6Pack of .5L Bottles

### ■ AIR FILTER ELEMENT

Part No.	Description
70243712	Element, Air Filter

### ■ STEP SAVER KITS

Step Saver Kits provide all of the parts required to perform common repair tasks such as piston ring replacement or valve replacement.

Part No.	Description	Contents
97338107	Kit, Valve/Gasket	Valve wearing parts and head gaskets that are destroyed in replacing valve parts.
97338115	Kit, Ring/Gasket	Complete set of piston rings, a crankshaft seal, and gaskets that are destroyed in breaking the unit down to replace the rings.

### ■ CRANKCASE HEATER KIT

Crankcase heaters are recommended when ambient temperatures are consistently below 32°F (0°C). An easy-to-install external crankcase heater kit is intended for aftermarket use.

Part No.	Description
97330385	Kit, Crankcase Heater

### ■ VIBRATION ISOLATOR PADS

Vibration Isolator pads are designed to absorb 20% - 40% of the sound and vibration of your compressor.

Part No.	Description
32320681	Pad, Vibration isolator - 4" X 4" SP-NR
32320699	Pad, Vibration isolator - 5" X 5" SP-NR
32321002	Pad, Vibration Isolator - 4" X 4". NRC
32321028	Pad, Vibration isolator - 5" X 5". NRC
32321010	Pad, Vibration Isolator - 6" X 6" NRC

SP-NR: Steel plate bonded between a NR pad and a non-skid oil-resistant ribbed neoprene top pad.  
NRC: Two ribbed neoprene pads bonded to 1/2" cork pad.

### ■ MULTIPURPOSE AIR HOSES

These air hose assemblies are heavy duty, light weight hoses designed for 300 PSIG working pressure.

Part No.	Description
32323750	Hose, Air- 3/8" x 25' (1/4" Male NPT)
32323768	Hose, Air - 3/8" x 50' (1/4" Male NPT)
32323776	Hose, Air- 3/8" x 100' (1/4" Male NPT)

### ■ Y - STRAINERS

Y-strainers are designed to prevent foreign particles from moving downstream

Part No.	Description
32323628	Y-Strainer, 1/4"
32323636	Y-Strainer, 1/2"

### ■ AUTOMATIC DRAIN VALVE ADDITION KIT

An automatic drain valve eliminates the need for manual tank draining.

Part No.	Description
32311219	Kit, Automatic Drain Valve



**PORTLAND  
COMPRESSOR**  
*Experience You Can Depend On*  
**800-542-8300**

**PORTLAND  
COMPRESSOR**  
*Experience You Can Depend On*  
**800-542-8300**